

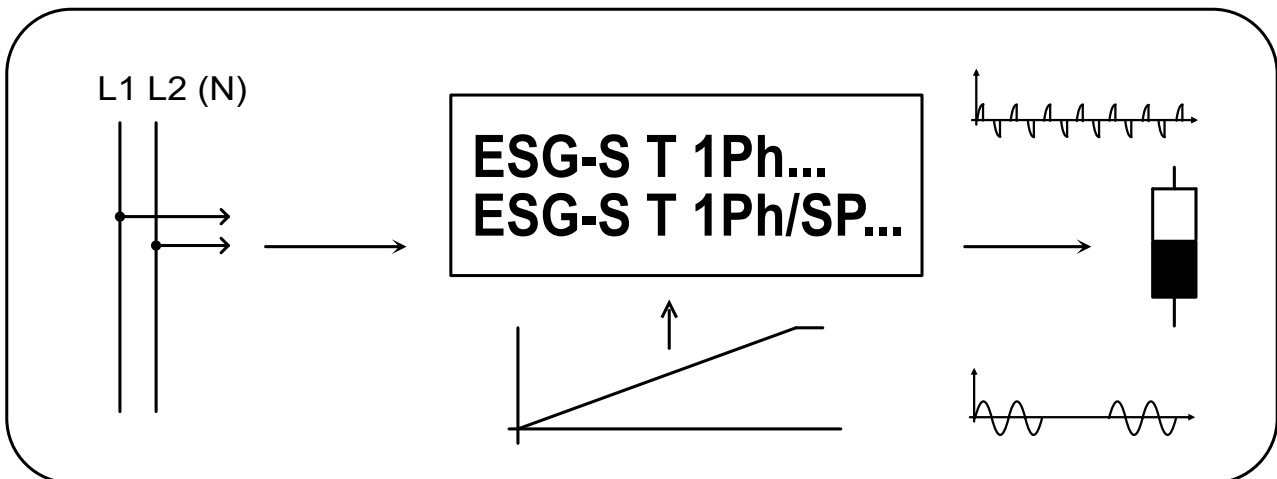

## Start-up instructions

### Thyristor controller Type: ESG-S T 1Ph, ESG-S T 1Ph/SP Three phase controller W1C



## Content

	Page
1. Important safety instructions.....	2
2. General instructions.....	2
3. Technical explanations on thyristor controllers.....	3
4. Installation of the thyristor controller ESG-S T 1Ph, ESG-S T 1Ph/SP.....	4
5. EMC-equitable assembly.....	4
6. Operation.....	6
7. Meaning of the clamp connections.....	7
8. Basic circuit.....	8
9. Survey of the individual types.....	9
10. Technical data.....	10

## 1. Important safety instructions

This manual contains instructions, which have to be observed for your personal safety and for the prevention of material damage. The instructions about your personal safety are highlighted with a warning triangle labelled with three exclamation marks, hints about material damages are listed with a warning triangle and one exclamation mark.



### **Danger-symbol**

Personal injury **may** occur, if appropriate safety precautions are not taken.



### **Caution-symbol**

Material damages may occur, if appropriate safety precautions are not taken into account.



### **Disposal regulations**

The devices contain electrical components and must not be disposed together with household garbage. The devices for disposal have to be recycled according to local and currently valid regulations for electronic waste.

### **Qualified personnel**

The corresponding device/system may only be set up and operated in conjunction with this documentation. Commissioning and operation of the device/system may only be performed by **qualified personnel**. Qualified personnel within the meaning of the safety instructions in this documentation are persons with the authority to put electric circuits into operation, provide ground connections and label them according to current safety regulations.

The device should only be used in applications described in this document. The reliable and proper use of the product depends on appropriate transport, storage, installation and careful commissioning.

## 2. General instructions

### **Use of the document**

This instruction should demonstrate the technical application possibilities of the thyristor controller to the engineer in charge.

### **Target group**

The document should assist the user during commissioning. It also helps in case of service and maintenance work. It supports the planner and project engineer with the conception of new plants.

### **Necessary competence**

Generic skills in the field of electrical engineering are necessary.

### **Validity**

The present document is valid for the thyristor controller of the type ESG-S T 1Ph, ESG-S T 1Ph/SP. It contains the currently valid description of the unit. We reserve the right to attach new descriptions of the devices. This involves types and options with modified version status of the technical documents.

### **Standards and approvals**

The thyristor controller of the type ESG-S T 1Ph, ESG-S T 1Ph/SP are based on the IEC/EN 60947-4-3 standard.

### **Disclaimer**

It lies within the responsibility of the plant manufacturer of the technical equipment or machine to ensure the proper overall function. The producer can not guarantee all properties of the overall system or the machine.

### 3. Technical explanations on thyristor controllers

The thyristor controller is more and more used in sectors in which bigger loads of ohm and inductive loads have to be regulated.

Due to its modular, compact construction and its controlling by a continual control signal, these wattage regulators become a perfect device for industrial control of wattage input. The power element of the thyristor controller consists of six antiparallel connected thyristors, the isolated cooling system and the electronic regulation and watching.

#### Type description:

ESG-S T 3Ph...	three phase controller, phase angle control
ESG-S T 1Ph...	alternating current power controller single-phase, phase angle control
ESG-S T 3Ph/SP...	three phase controller, multicycle control
ESG-S T 1Ph/SP...	alternating current power controller single-phase, multicycle control

#### Voltage supply:

Different values of mains voltage are balanced so that any voltage variability of the load is avoided.

#### Construction:

The thyristor controller agrees with Low voltage directive: 2014/35/EU, EN60947-4-3 and EMC Directive: 2014/30/EU, EN60947-4-3 KI.A.

The thyristor controller ESG-S T 1Ph... is integrated within a plastic housing (PA, UL 94 V-0). It consists of three basic elements:

- power element with cooling system and thyristor switching facility
- control unit with electronic starting and control system (diagnostic indicator, regulation port etc.)

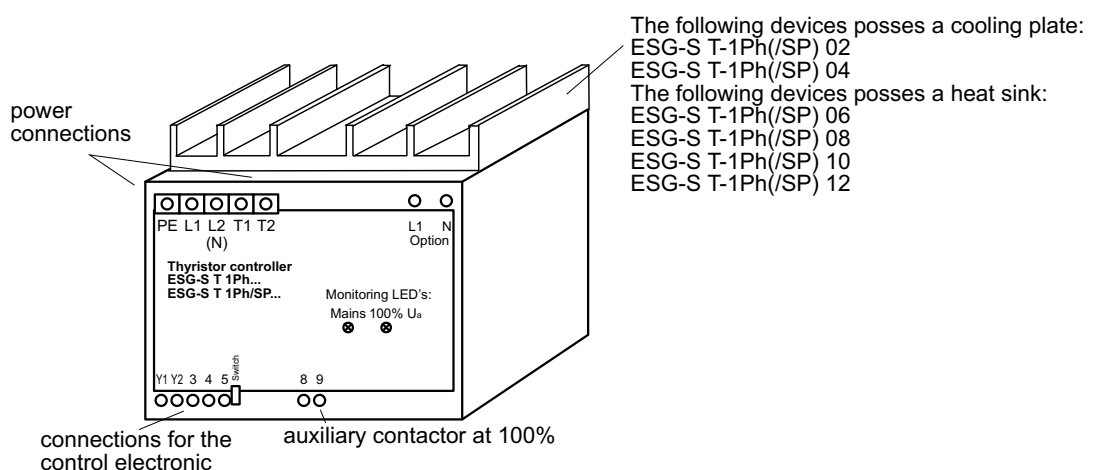

## 4. Installation of the thyristor controller ESG-S T 1Ph, ESG-S T 1Ph/SP

The built-in device according to IP 40 has to be mounted in a housing or a switchboard panel. Take care of adequate cooling (separate ventilation, for instance). The environment temperature must not exceed the value of 50°C. The device is to be mounted on a vertical plane, avoiding that the ventilating pipes of the cooling element are not placed vertical. The device has to be mounted in a dry room.

Further conditions to the operating area:



- protection from dust and moisture
- protection from aggressive atmosphere
- free from vibrations

No other devices should be placed closer than 50 to 100mm to the device, in order to provide adequate cooling.

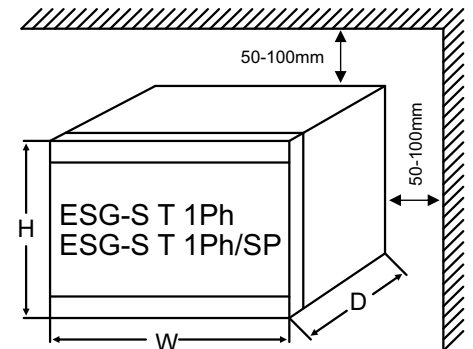

The housing design according to IP 54 (Option) can be mounted in places which are not protected from dust and humidity.

### Wiring the device:



The mains connections (L1, L2 (N)) have to be connected by using a disconnecting switch and usual fuses.

The connection for mains cable and the connections for controlling have to be laid in channels and protector tubes.

The electric installation always has to comply with the essential protection requirements of the European Low Voltage Directive 2014/35/EU and Electromagnetic compatibility Directive 2014/30/EU.

## 5. EMC-equitable assembly

According to EMC standards thyristor controllers are regarded as components, which do not fulfil any intended use by themselves. The devices constitute a functional unit of the entire plant. The control electronics of the thyristor controllers are implemented according to valid EMC standards.

The builder of the plant has to supply the plant with appropriate mains chokes and mains filters. These components can also be obtained from us. Thyristor controllers with multicycle control usually do not require any additional mains filter circuit.

It should be noted that the standards of the resource category A are not sufficient in a special industrial sector, for example if sensitive measuring channels are affected. In this case, the user has to apply equipment of class B.

The class A is the usual class of equipments, which is normally intended for the use in the industrial sector. The devices are connected to the industrial network via an assigned transformer. Power controllers of class B are required if they should be used in the area of industry and small-scale industry and if they should be connected to the public low-voltage system.

### Use of mains chokes:

On the input side of the thyristor controllers, mains chokes reduce the current-dependent line reactions and effect an improvement of the performance factor. This reduces the current harmonics and improves the mains quality. The use of mains chokes is particularly recommended when connecting thyristor controllers with phase angle control to a grid-feeding point and when other electronic devices are attached to this network.

**Use of mains filters:**

Radio interference filters and mains filters (combination of radio interference filter and one mains choke) serve for protection against high-frequency disturbances, which are sent out via the power cable or the radiation of the power cable. The high-frequency disturbances should be limited to a mandatory or legal degree. Mains filters should possibly be mounted close to the thyristor controller and moreover it is necessary to ensure that the connecting cable between the thyristor controller and the mains filter is as short as possible.

**CAUTION:** The mounting surfaces of the thyristor controllers and the radio interference filters have to be free from paint and well conducting in the high-frequency range.

Furthermore, mains filters have leakage currents, which may become significantly larger than the nominal values in case of failure (phase failure, unbalanced load). To avoid dangerous voltages, the mains filters have to be grounded. As the leakage currents are high-frequent disturbances, the grounding measures have to be low-resistance and extensive.

With leakage currents, which exceed the value of 3,5mA, VDE 0160 or EN 60335 specify that either:

- the cross section of the protective conductor has to be  $\geq 10\text{mm}^2$ ,
- the protective conductor has to be monitored on interruption or
- a second protective conductor has to be laid.

**Shielding measures:**

Shielding measures help to reduce the radiated interference energy. Electrical lines between thyristor controller and load can be laid shielded. Thereby the shield must not replace the PE line. Four-wire cables (three phases + PE), whose shield is double-sided and extensive laid on earth potential (PES), are recommended. The shield must not be applied over the connecting wires. Interruptions of the shielding e.g. in the case of clamps, contactors, mains chokes etc. have to be bridged with low-resistance and appropriate space considerations.

In practice this can be done for example by interrupting the shield close to the assembly and then connecting it extensively with the earth potential (PES, shield clamp). The free cables, which are not shielded, should not be longer than 100mm.

**Grounding measures:**

Grounding measures are absolutely necessary to fulfil legal provisions. They constitute a prerequisite for an efficient use of further measures such as filters and shielding. All conductive, metallic housing components have to be electroconductive connected with the earth potential. For the EMC-measure, the important factor is not the cable's crosssection, but its surface, since this is where high frequency current flows to earth. Once again, all grounding points have to be led directly, extensively and with low-resistance to the central grounding point (equipotential bonding bar, star-shaped grounding system). The contact points have to be free from paint and corrosion (use galvanized mounting plate and materials).

## 6. Operation



To begin with, all electrical connections have to be established according to the circuit diagrams L1, L2 (N), T1, T2. The thyristor controller has to be connected to the mains according to the electric regulations (Low Voltage Directive) so that they can be separated by disconnecting switches (e.g. load interrupter, contactor etc.) from the mains.

Cabling must be performed by personnel who are qualified to work low voltage electrical equipment. Before any connection or disconnection, make sure that the power and control cables and wires are isolated from the voltage sources.

### **Recommended connection:**

The mains connections, the connection to the load and the control connections have to be laid in separate cables. In order to avoid faults the electronic control connections should be separated from the power wires and/or contactor control wires and one should twist the control wires. In order to reduce risks related to the effects of electromagnetic interference depending on the installation of the product please consider the rules for electromagnetic compatibility.

### **Fuses:**

The net-lateral security depends on the recommended and/or the used cross-section of a wire and has to be made according to DIN 57100 part 430/VDE 0100 part 430/6.81 (Low Voltage Directive).

## 7. Meaning of the clamp connections

<b>Control voltage</b>		
<b>L1, L2 (N)</b>	connection of 230V/50Hz (optional: any other voltages can be realized upon request)	
<b>Option</b>	external supply voltage, monitoring for temperature exceedance	
<b>Power output terminals</b>		
<b>T1, T2</b>	load (cf. table "Survey of the individual types", p. 9)	
<b>Activation terminals</b>		
<b>Y1, Y2</b>	activated	closed
	ready	open
<b>Control input terminals</b>		
<b>3, 4</b>	setpoint signal 0...10V DC or 0...20mA DC (reversible with switch)	
<b>5</b>	reference voltage 10V DC (voltage supply for potentiometer control)	
<b>Relay output terminals</b>		
<b>8, 9</b>	relay output (activated if 100% of output voltage is reached)	

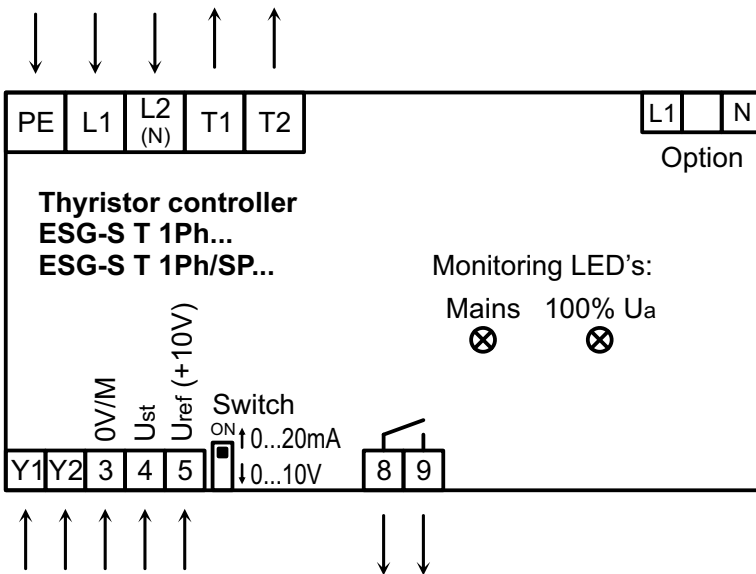

<b>Meaning of the LED's</b>	
<b>Mains</b>	mains voltage is available, device is ready for use
<b>100% <math>U_a</math></b>	device has reached full conduction

## 8. Basic circuit

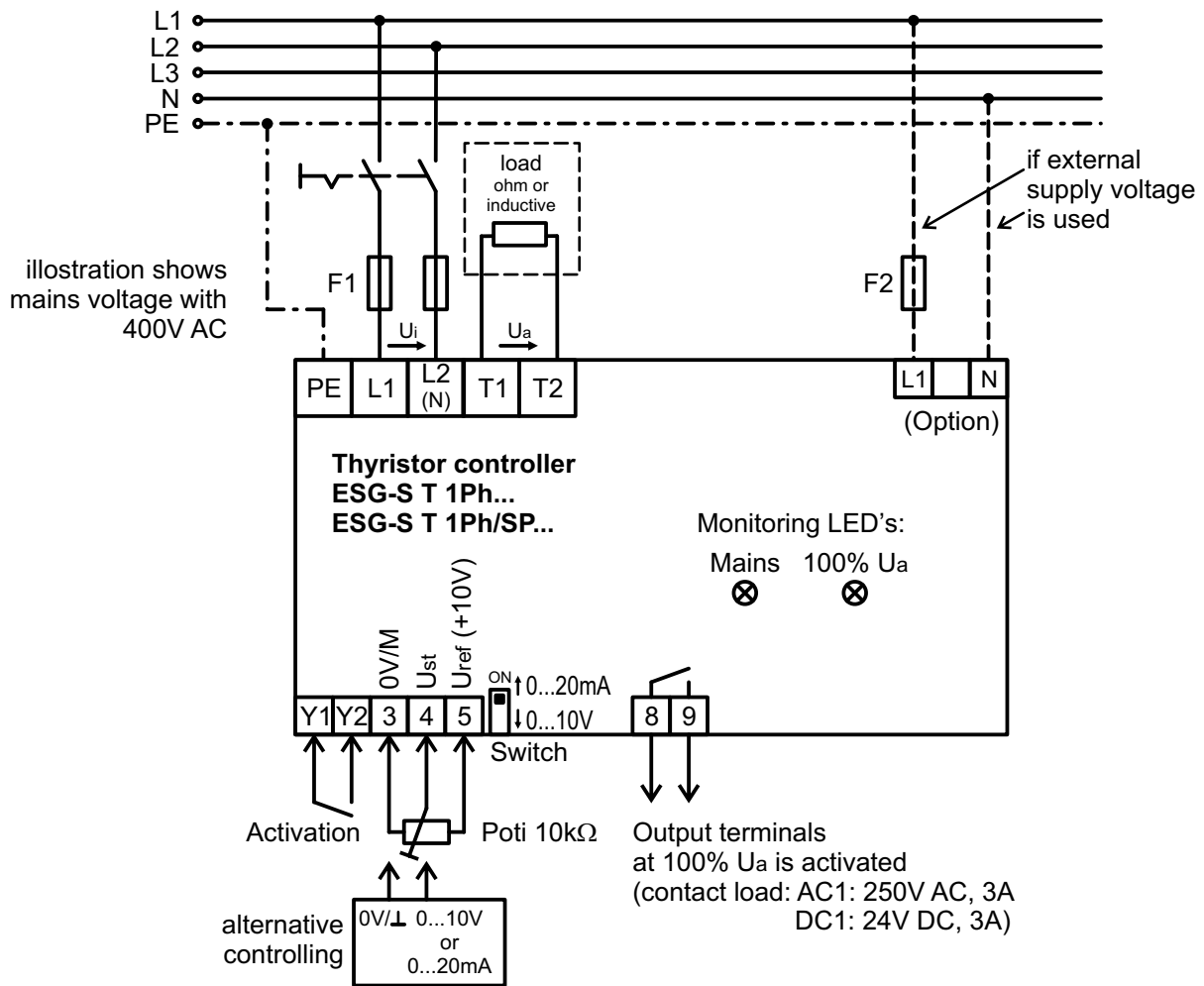



## 9. Survey of the individual types

Type*	max. load current	rec. semi-conductor fuses	mains fuse	rec. cross-section	max. power	power loss at nominal rating	Weight	Frame size	Dimensions WxHxD
	[A]	[A]	[A]	[mm <sup>2</sup> ]	[kW]	[W]	[kg]		[mm]
ESG-S T 1Ph 02	2	4	6	1,5	0,8	2,5	0,4	A	100x77x110
ESG-S T 1Ph 04	4	4	6	1,5	1,6	4,5	0,4	A	100x77x110
ESG-S T 1Ph 06	6	6	10	1,5	2,4	6,5	0,5	B	100x100x110
ESG-S T 1Ph 08	8	8	10	2,5	3,2	9,0	0,5	C	100x108x110
ESG-S T 1Ph 10	10	8	16	2,5	4,0	11,0	0,5	C	100x108x110
ESG-S T 1Ph 12	12	10	16	2,5	4,8	13,0	0,5	C	100x108x110

Errors and technical modifications excepted (Date: 2017/02)

\* The given details also apply to the version with multicycle control ESG-S T-1Ph/SP...

The given values refer to the operation voltage of 400V AC. The values given for overload refer to a surrounding temperature exceed of max. 50°C and an installation altitude of 1000m.

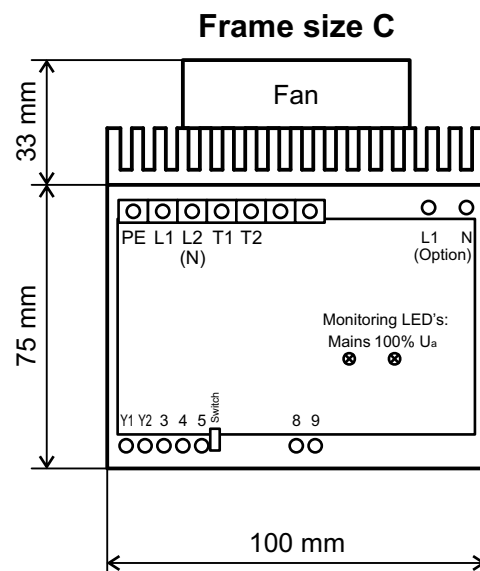
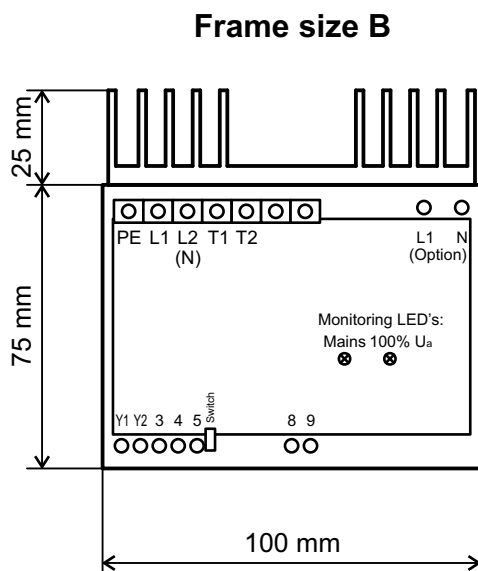
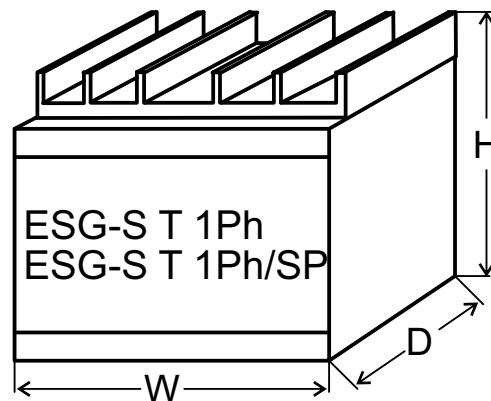
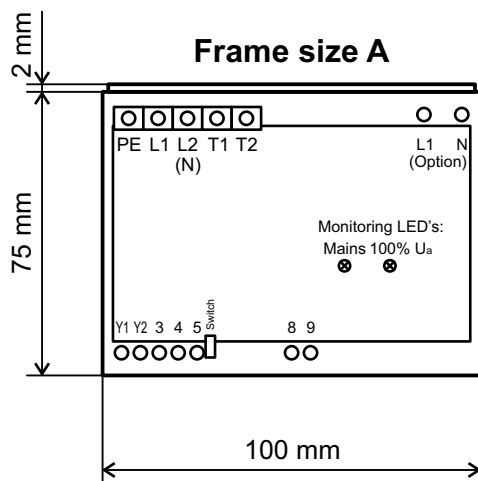

## 10. Technical data

<b>Voltage of power circuit</b>	standard configuration: internal supply (from mains voltage) option: 24V DC, 110V AC, 230V AC
<b>Mains voltage</b>	230V AC (standard configuration) (110V AC, 400V AC, 440V AC optionally possible)
<b>max. current load</b>	cf. table "Survey of the individual types", p. 9 (2...12A)
<b>Frequency</b>	48Hz...62Hz
<b>Phase sequence</b>	self-synchronizing
<b>Kind of loads</b>	ohmic and inductive load
<b>Kind of controlling</b>	phase angle (optional: multicycle control)
<b>Test voltage</b>	according to VDE 0160, Tab. 6 / DIN EN50178 table 18
<b>Kind of protection</b>	<ul style="list-style-type: none"> <li>• housing: IP 40</li> <li>• clamps: IP 23</li> </ul>
<b>Moisture class</b>	F according to DIN 40040
<b>Ambient temperature</b>	<ul style="list-style-type: none"> <li>• operation: 0...45°C</li> <li>• storage: -10...70°C</li> </ul>
<b>Vibration resistance</b>	4G
<b>Mounting</b>	proposed to be mounted on a DIN rail (DIN 46277-3; 35x7,5mm)
<b>Housing</b>	PA, UL 94 V-0
<b>Indicating operation state</b>	<ul style="list-style-type: none"> <li>• operation: LED „green“</li> <li>• level 100%: LED „green“</li> </ul>
<b>Signal contact</b>	level 100% 250V AC 3A; 24V DC 3A
<b>CE-marking</b>	Declaration of Conformity 2014/35/EU (Low voltage directive) EMC Directive 2014/30/EU for industrial environments
<b>Regulations</b>	VDE 0160, EN 60204, IEC 947-4-2
<b>Inputs</b>	<ul style="list-style-type: none"> <li>• 0...10V DC</li> <li>• 0...20mA DC</li> <li>• potentiometer input: 2,5kΩ...10kΩ</li> </ul>

Errors and technical modifications excepted (Date: 2016/05)